



RB-30/RB-40

Manual Version 1.1



 F-4, Building C, Zhongxiu Technology Park, No.3 Yuanxi Road, Wuxi, 214125, Jiangsu, China



(86)510-85187718



frsky@frsky-rc.com



www.frsky-rc.com

FrSky Electronic Co., Ltd.

Introduction

The RB-30/RB-40 utilizes all the trusted attributes of the previous Redundancy Bus series along with adding new features to meet the needs of an ever-growing range of users.

The upgraded redundancy hub

Previous redundancy bus models offered a dual-power with a dual-receiver design, the RB-30/RB-40 allows the user to use a triple redundancy by adding a multiplex port (RX3 IN / SBUS Out) and uses a set of standard XT30/XT60 plugs which provides a safe and efficient way to provide power.

Up to 24 PWM channels with overload protection

The RB-30/RB-40 supports connecting up to 24 high-voltage servos with overload protection added to each output channel. Eight of the channels (CH1-8) are equipped with current sensors.

The diversified sensors

The RB-30/RB-40 is an extensive sensor module with a built-in gyroscope that supports model stabilizing functions and includes other diversified telemetry feedback like the voltage, power consumption, altitude, and a lot more. It can be used as an alternative to using a GR or S series receiver.

NFC Switch & Automatic data logging functions

The non-contact NFC switch is an external device that enables the power to be switched on/off on command without the need to plug/unplug the battery connections. Once power is connected, the black-box function is automatically activated and immediately starts recording the data.

Menu scroll button, LCD screen & CNC case (RB-40 Only)

The RB-40 features a display screen that is comparable in size to one found on the X-Lite series radio. Navigating and configuring telemetry data is even more convenient thanks to the scroll button. Even considering all these features while maintaining durability, the RB-40 weighs only 260 grams thanks to the hybrid design of carbon fiber and aluminum materials.

Overview

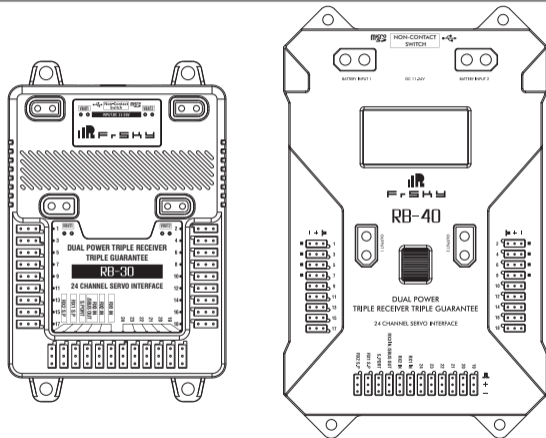

- RX1 S.P-connect to the S.Port of RX1
- RX2 S.P-connect to the S.Port of RX2
- S.Port-connect to the S.Port of FrSky products with S.Port
- RX1 IN~RX3 IN-connect to the SBUS OUT Port of the receiver.
 - * The RX3 IN can be switched to S.BUS OUT by the script or the Scroll button or the Freelink App.
- BATTERY INPUT1&BATTERY INPUT2-connectors for batteries, supply power for RB-30/RB-40 and connected receivers.
- OUTPUT1&OUTPUT2: SBEC OUTPUT, Continuous Current: 2*15A@5~8.4V (RB-30) / 2*30A@5~8.4V(RB-40)

Note: Use voltage above 16.8V if you want to reach 30A@8.4V please.

CH1~CH24-connect up to 24 servos (PWM)

*CH24 is used for the external LED when enable the stabilization function.

External Blue LED	State (Self-check)
ON	In process
OFF	Completing

Specifications

- Dimension: RB-30: 114.4*73.4*18.7mm
RB-40: 163.2*100*23.5mm
- Weight: RB-30: 100g / RB-40: 260g
- Power connector: RB-30: XT30 / RB-40: XT60
- Number of servos: up to 24
- Operating temperature: -20°C~75°C
- Recommended input voltage range: DC 11~26V

Features

- Dual Power & Triple Receiver Guarantee
- High-voltage Servo Supported (Up to 24 PWM servos)
- Overload Protection on Each Channel
- Channel 1-8 with Current Detection
- Supports Stabilization Function with Built-in Gyroscope Sensor
- Multiple configuration methods (Lua script and FreeLink)
- Compatible with FrSky S.Port products
- Various S.Port Telemetry Feedbacks (Voltage, Current, Power Consumption, etc.)
- Black Box Data Record Function
- Non-contact Switch (Optional)
- LCD Screen with Menu Scroll Button (Only RB-40)
- CNC Aluminum & Carbon Fiber Case (Only RB-40)

Layout: (take RB-30 for example)

Dual-Frequency System (2.4GHz ACCESS & R9 SERIES) with RB Device

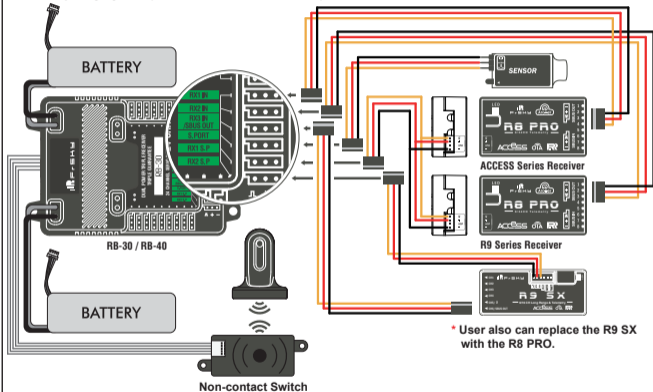

* User also can replace the R9 SX with the R8 PRO.

* To use multi ACCESS receivers binding with the same ISRM module, please modify the UID for different receivers.

Introduction about two battery power supply

The RB-30/RB-40 supports DC 11V~26V. When two batteries are inserted at the same time, the higher SBEC output will be selected to power the device. The maximum continuous current is 30A.

Application of batteries with different capacity, number of cells and chemistry type is allowed.

Please ensure output power on one of the two power supplies is no less than the maximum operation power of the connected devices (servos, etc.), or insufficient power supply on the connected devices may occur.

The RB-30/RB-40 supports two SBEC outputs, DC 5-8.4V.

The output voltage can be adjusted by the script or the Scroll button or the Freelink App. The supply voltage of CH1~CH24 and RX1~RX3 comes from the highest voltage.

StabFunc.	Enable
RX3 SBUS	IN
Vout 1 Set	6.6V
Vout 2 Set	5.0V
Rx Protocol	ACCESS

(RB-40)

* The Stabilization function can be enabled or disabled by the script or the scroll button or Freelink APP.

* The RX3 SBUS IN can be switched to SBUS OUT by the script or the scroll button or Freelink APP.

Caution: 1. Do not connect power supplies to CH1~CH24, S.PORT, RX1 S.P, RX2 S.P, RX1 IN ~RX3 IN.
2. Select the ACCESS/ACCST Rx Protocol before using it.

Channel Mapping:

1. The RB-30/RB-40 PWM 1 outputs the RX1 CH1 in default, if RX1 CH1 is not normal, it will switch to output the RX2 CH1.
2. You can set the PWM output of RB-30/RB-40 from which RX channel.

RB PWM1 RX1 CH1 RX2 CH1

Ch 1 Map	1	1	1	RX3 CH1
Ch 2 Map	2	2	2	
Ch 3 Map	3	3	3	
Ch 4 Map	4	4	4	
Ch 5 Map	5	5	5	
Ch 6 Map	6	6	6	
Ch 7 Map	7	7	7	
Ch 8 Map	8	8	8	

Ch 9 Map	9	9	9
Ch10 Map	10	10	10
Ch11 Map	11	11	11
Ch12 Map	12	12	13
Ch13 Map	13	13	13
Ch14 Map	14	14	14
Ch15 Map	15	15	15
Ch16 Map	16	16	16

Ch17 Map	0	0	0
Ch18 Map	0	0	0
Ch19 Map	0	0	0
Ch20 Map	0	0	0
Ch21 Map	0	0	0
Ch22 Map	0	0	0
Ch23 Map	0	0	0
Ch24 Map	0	0	0

* The Stabilization function should be disabled when you set the channel mapping.

Failsafe set:

The channel outputs the value you set when into Failsafe.

Ch 1 FailSafe	800
Ch 2 FailSafe	800
Ch 3 FailSafe	800
Ch 4 FailSafe	800
Ch 5 FailSafe	800
Ch 6 FailSafe	800
Ch 7 FailSafe	800
Ch 8 FailSafe	800

* You can set up it by the script or the Scroll button or Freelink APP.

Overcurrent protection and current detection & state monitor

CH1~CH8 is equipped with current detection sensor, which can detect current in real time. CH1~CH24 have overload protection. RB-30/RB-40 also monitors the status of each interface in real time.

Ch 1 Curr	0.3A
Ch 2 Curr	0.0A
Ch 3 Curr	0.1A
Ch 4 Curr	0.0A
Ch 5 Curr	0.0A
Ch 6 Curr	0.0A
Ch 7 Curr	0.0A
Ch 8 Curr	0.0A

(RB-40)

Rx1	No Connect
Rx2	No Connect
Rx3	No Connect
Sport1	Not Connect
Sport2	Not Connect

(RB-40)

Vbat1 Volt:	16.0V
Vbat1 Curr:	0.3A
Vbat1 Powe:	46mAh
Vout1 Volt:	6.6V
Vbat2 Volt:	0.0V
Vbat2 Curr:	0.0A
Vbat2 Powe:	0mAh
Vout2 Volt:	0.1V

(RB-40)

If current overload, the affected servo output will be disconnected from the power supply while remaining servo outputs are still powered.

The allowed continuous current output on CH1~CH24, S.PORT, RX 1IN, RX 2IN, RX3 IN is 5A. When the continuous current is over 10A, the RB-30/RB-40 will activate overload protection immediately 23°C.

Temperature	I _{hold} (A)	I _{trip} (A)
23°C	5.00	10.00
50°C	3.95	7.90
70°C	3.35	6.70

Note

I_{hold} means the maximum current passes through the device without tripping under the above three conditions.

I_{trip} means the minimum current passing through the device will cause trip under the above three conditions.

About the telemetry values:

TELEMETRY	12/13	TELEMETRY	12/13	TELEMETRY	12/13	TELEMETRY	12/13
1: AccV	0.13g	*	8: CH6A	2.10A	*	15: RSSI	63dB
2: AccZ	-9.17g	*	9: CH7A	0.00A	*	16: RBCS	CH02
3: CH1A	0.00A	*	10: CH8A	0.00A	*	17: RBS	Rx2 Lost
4: CH2A	0.00A	*	11: RB1U	8.20U		18: RB1C	68mAh
5: CH3A	0.00A	*	12: RB1A	0.20A		19: RB2C	0mAh
6: CH4A	0.00A	*	13: RB2U	6.34U		20: RxBt	4.9U
7: CH5A	0.00A	*	14: RB2A	0.00A		21: RBES	CH17

All values above will be transmitted to FrSky radio system in real time

AccX/Y/Z—Accelerometer triaxial parameter

CH1A~CH8A—The current telemetry of CH1 ~CH8

RBnC: total power usage of battery n

RBnV: the voltage of battery n

RBnA: the current of battery n

RBCS:

1.

Display	Definition for Value
OK	normal
CHn / RXn_IN / SBUS_OUT / RX3_IN	CHn / RXn_IN / SBUS_OUT / RX3_IN overload

2. When using SD logs function, if the RBCS has a non-zero value, such as 64, Convert 64 to binary 1000000. As you can see from the table, the channel 7 overloader or Voltage less than 4V.

BitX	Definition for Value
Bit n (n≤15)	0: channel n+1 normal 1: channel n+1 overloader or Voltage less than 4V

RBES: indication of CHN status.

Display	Definition for Value
OK	normal
CHn	CHn (n:17~24) overload

RBS: indication of receiver status.

Display	Definition for Value
RX OK	normal
RXn_FS	Receiver n Failsafe
RXn_LOSTFRAME	Receiver n Lost frame
RXn_PHYSICAL_CONNECTION_LOST	Receiver n Physical connection lost
RXn_NO_SIGNAL	Receiver n No signal

3. When using SD logs function. if the RBS has a non-zero value, such as 256, convert to bin 100000000, means Rx2 Physical connect break off. (0 is normal)

Bit 0	Bit 1	Bit 2	Bit 3	Bit 4	Bit 5
Rx1 overloader	Rx2 overloader	Rx3 SBUS overloader	Rx1 failsafe	Rx1 framelost	Rx2 failsafe

Bit 6	Bit 7	Bit 8	Bit 9	Bit 10	* Bit 11	* Bit 12	* Bit 13	* Bit 14
Rx2 framelost	Rx1 Physical connect break off	Rx2 Physical connect break off	Rx1 No signal input	Rx2 No signal input	Rx3 failsafe	framelost	Rx3 Physical connect break off	Rx3 No signal input

*** Note: "RX3 SBUS IN" STATE.**

Attention:

1. Make sure both of the receivers output the same signal. For example, when S8R and X8R are used together, disable Stab function on S8R, or they will output different signals.

2. RB-30/RB-40 will manage the telemetry of the two receivers automatically after connecting the devices.

About the Stabilization function

Channels

Number of channel	Corresponding parts on the model	Full name
CH1	AIL 1	Aileron
CH2	ELE 1	Elevator
CH3	THR	Throttle
CH4	RUD	Rudder
CH5	AIL 2	Aileron
CH6	ELE 2	Elevator

Number of channel	Corresponding parts on the model	Full name
CH7	User-defined	
CH8	User-defined	
CH9	No mark	Gyro gain adjustment
CH10&CH11	No mark	Flight modes
CH12		Self-check activation switch

Gyro gain adjustment of CH9: When the the value of CH9 is in the center, the gain is zero. The gain increases as the value gets bigger. Until the value is $\pm 100\%$, the gain reaches maximum.

Attentions

CH1~CH8 should be connected to the corresponding servos.

Set up your model and receiver

You need to complete calibration of Accelerometer about the six positions via the RB-30/RB-40.Lua/FreeLink APP firstly.

Step1: Connect your servos follow the channel list according to your model.

Step2: Set you radio follow the channel list.

Step3: Choose the Wing Type via the configuration tool (RB-30/RB-40.Lua/FreeLink APP).

Step4: Choose the AUTO LEVEL mode, check the model servo feedback.

Step5: Choose the manual mode, check servo feedback via transmitter.

Quick Mode

It supports stabilization mode and manual (six-axis off) mode and configured through CH10. What's more, an urgent mode is added to configure automatic level mode default through CH12. The precise configuration is given below.

Channel	Position	Flight Mode
CH10	SW Down	None
	SW Mid	Stabilization Mode
	SW Up	Automatic Level Mode
CH12	SW Down	Urgent Mode (Automatic Level Mode)

Note: The default mode of RB-30/RB-40 is Quick Mode. When re-flashing firmware of RB-30/RB-40 or replacing with a new one, the preset mode will be erased.
- If Quick mode is applied, there is no Knife Edge or (3D) Hover mode.
- CH11 is not used when using Quick Mode.

Modes

Conventional Model	Stabilization
	Automatic level
	Hover
	Knife-edge

Delta Wing	stabilization automatic level
Flying Wing	
V-tail	

The Model types could be enabled via RB-30/RB-40.Lua. or Fremlink APP.

Conventional model

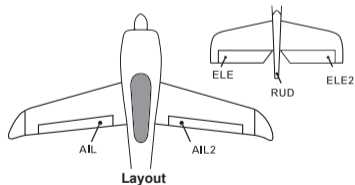

The available flight modes can be assigned to CH10 and CH11 with three-position switches.

Flight mode	Stabilization	Automatic level	Hover	Knife-Edge	Off
CH10 (3 pos SW)	CH10>M+H (CH10 SW Down)	CH10>M+H (CH10 SW Down)	CH10>M+H (CH10 SW Down)	CH10<M-H (CH10 SW Up)	CH10 SW-mid
CH11(3 pos SW)	M-H<CH11<M+H (CH11 SW Mid)	CH11>M+H (CH11 SW Down)	CH11<M-H (CH11 SW Up)	M-H<CH11<M+H (CH11 SW Mid)	

Delta wing & Flying wing & V-tail

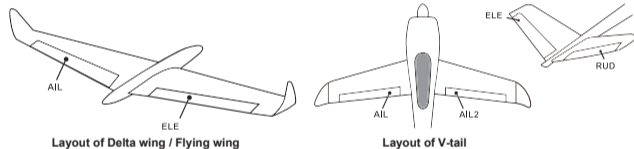

The available flight modes can be assigned to CH10 with a three-position switch.

Flight mode	Stabilization	Auto Level	Off
CH10	CH10>M+H (CH10 SW Down)	CH10<M-H (CH10 SW Up)	CH10 SW-mid

When Delta wing/Flying wing/V-tail is selected, the signal produced by the transmitter should be without active mixes on the channels related to AIL and ELE. RB-30/RB-40 will mix the AIL(CH1) and ELE(CH2) input signal with a fixed mix percentage automatically. Signals on CH4~CH8 then behave as required by user.

M: represents a neutral signal period (1500 μ s)

H: represents the time of required signal change to activate the mode (50 μ s). When the factory settings are selected, the switch position shown above represents the required modes.

Off: When the mode is activated, RB-30/RB-40 will transmit the received commands produced by the transmitter to the model without compensating.

Flight mode:

Stabilization: When the mode is activated, RB-30/RB-40 will compensate with external forces (wind) as soon as receiving commands from the transmitter. This function is used to enhance the stability of the model on three axis (Pitch, Roll, Roll). CH9 could be used to adjust gyro gain by assigning a knob or a slider, changing the sensitivity of the counteracting signal produced by the internal three-axis gyroscope.

Automatic level: When the mode is activated, RB-30/RB-40 will make the model return to level orientation with internal three-axis accelerometer and three-axis gyroscope on AIL and ELE channels after the sticks being released to neutral. RUD channel works in stabilization mode only.

Hover: When the mode is activated, RB-30/RB-40 will make the nose of the model straight up with internal three-axis accelerometer and three-axis gyroscope on RUD and ELE channels. Under this mode, AIL is used to control the rotation of the model and THR adjust the altitude. AIL channel works in stabilization mode only.

Knife-edge mode: When the mode is activated, RB-30/RB-40 will roll the plane on a certain side (wing points up) with internal three-axis accelerometer and three-axis gyroscope on RUD and AIL channels. While the mode steering is done with ELE, altitude will be maintained with THR/RUD. ELE channel operates in stabilization mode only.

Configuration

Methods: APP configuration

FrSky radio LUA configuration

Parameters configuration: Wing type, mounting type, gain setting, offset angle setting, accelerometer calibration.

APP (IOS/Android) configuration:

- Connect the RB-30/RB-40 to the App with AirLink S.

The menu screen on the home page is displayed below:

RB30/RB40 STAB Set



You can download the app and learn more about how to use it.



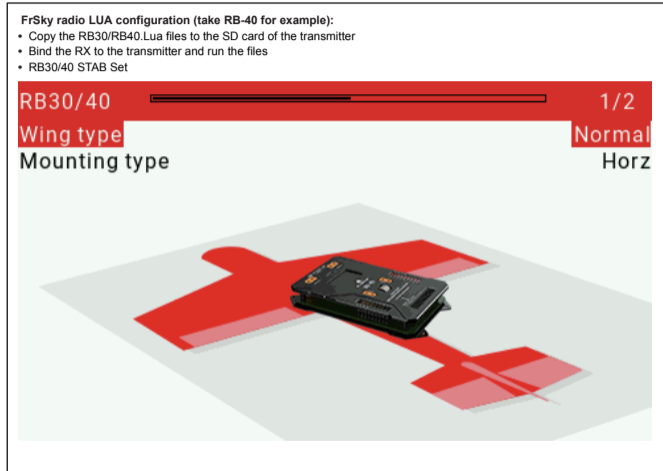
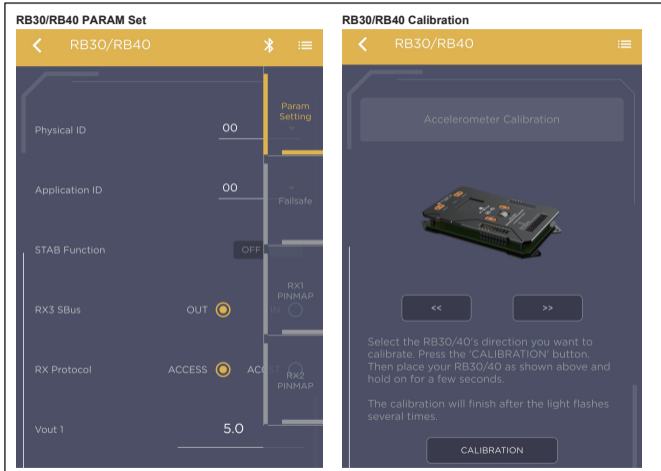

RB30/40		2/2
Stab functions		Disable
Quick Mode:		Enable
CH5 mode		AIL2
CH6 mode		ELE2
AIL direction		Normal
ELE direction		Normal
RUD direction		Normal
AIL2 direction		Normal
ELE2 direction		Normal
AIL stab gain		50
ELE stab gain		80
RUD stab gain		100

- RB30/40 PARAM Set

RB30/RB40		1/4
Stab function		Disable
RX3 sbus		OUT
VOut1(V)		5.0
VOut2(V)		5.0
Rx protocol		ACCESS

- RB30/40 Calibration :

Step 1. [Front side up]

Open the script, follow the instructions, place RB30/40 on the front, and click OK. When the LED lights are flashing and the calibration is completed, click next step.

RB30/RB40	2/4
CH1 failsafe	800
CH2 failsafe	900
CH3 failsafe	1000
CH4 failsafe	1100
CH5 failsafe	1200
CH6 failsafe	1300
CH7 failsafe	1400
CH8 failsafe	1500
CH9 failsafe	1600
CH10 failsafe	1700
CH11 failsafe	1800
CH12 failsafe	1900

RB30/RB40	3/4
CH1 RX1 map	1
CH2 RX1 map	2
CH3 RX1 map	3
CH4 RX1 map	4
CH5 RX1 map	5
CH6 RX1 map	6
CH7 RX1 map	7
CH8 RX1 map	8
CH9 RX1 map	9
CH10 RX1 map	10
CH11 RX1 map	11
CH12 RX1 map	12

CH1 RX2 map	1
CH2 RX2 map	2
CH3 RX2 map	3
CH4 RX2 map	4
CH5 RX2 map	5
CH6 RX2 map	6
CH7 RX2 map	7
CH8 RX2 map	8
CH9 RX2 map	9
CH10 RX2 map	10
CH11 RX2 map	11
CH12 RX2 map	12

Place the RB30/40 in the following position

X::-0.03
Y::-0.01
Z::1.07



Press [Enter] when ready

Step 2. [Front side down]

RB30/40

1/1

Place the RB30/40 in the following position

X::-0.01
Y::0.00
Z::-1.06



Press [Enter] when ready

Step 3. [Top side down]

RB30/40

1/1

Place the RB30/40 in the following position

X::0.98
Y::0.01
Z::0.00



Press [Enter] when ready

Step 4. [Top side up]

RB30/40

1/1

Place the RB30/40 in the following position

X::-1.00
Y::-0.02
Z::-0.01



Press [Enter] when ready

Step 5. [Right side up]

RB30/40

1/1

Place the RB30/40 in the following position

X::0.00
Y::-1.00
Z::-0.01



Press [Enter] when ready

Place the RB30/40 in the following position

X::0.00
Y::1.02
Z::-0.01



Press [Enter] when ready

Calibration completed



Press [RTN] when ready

* The LED should be plugged into CH24 port before calibration.

The positive and negative values related to three-axis gyroscope and accelerometer make a total of six values that need to be acquired.

Please follow the on-screen instructions.

- Click the "Calibration" button and wait until the BLUE LED flashing, indicating the calibration on this orientation has been completed.
- Repeat the above step five times (remaining 5 dimensions). Placing RB-30/RB-40 in the required orientation, ensure all values (X, Y, Z, Mod) are 1.000 with the deviation of ± 0.1 .
- Press "Write" to save the data on RB-30/RB-40 when done.

Inspection of flight attitude

To ensure flight safety, checking the compensation direction of the model is strongly recommended.

Activating auto level mode will produce a strong deflection on AIL and ELE, which is used to check the response of aileron and elevator. Also, activating Knife-edge and Hover mode will have the same reaction on the rudder.



When the plane is rotated left or right (Roll), ailerons should have the correcting actions as illustrated above.

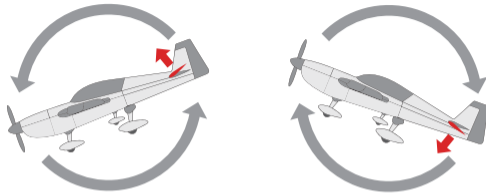

When the plane is rotated up or down (Pitch), elevators should have the correcting actions as illustrated above.

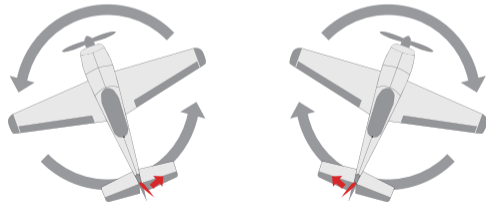

When the plane is rotated to left or right (Yaw), rudders should have the correcting actions as illustrated above.

 After changing the compensation direction, make sure to check it again on the actual model.

Note: If the compensation direction is incorrect, you can reverse the corresponding channel with the Lua Script (RB30/40 STAB Set 2/2) / FreeLink.

Self-check

Attentions

- Before self-check, please place the model on the ground (level surface).
- When the model is flying, aerodynamic balance is more important than level attitude, which results in that the model flies at a constant altitude with the nose slightly pointing up at low speed. To avoid the nose-diving of the model at high air speed, the user must ensure that the model is placed at a level or slightly-nose-up attitude during self-check.
- Always install RB-30/RB-40 straight and level in the model. If required, PC software could be used to adjust the angle of attack with the purpose of realizing the required setting. If the values set by the user is bigger than average ones, we advise to recheck the installation orientation of RB-30/RB-40.

Steps

- Turn on the transmitter and ensure that Ail (CH1), ELE (CH2), RUD (CH4), AIL 2(CH5) and ELE (CH6) are in the neutral position.
- Power on the model and start self-check. Ensure the auto level angle of the gyro and the neutral position of gimbal. Please don't touch/move the model until self-check finishes, or it may corrupt the calibration settings created during the procedure.
- Move the three-position sticks bound to CH12 three times in 3 seconds (up, mid, down). Then the BLUE LED will turn on, indicating self-check procedure is initiated. After that, the corresponding parts on the model will move. At last, the BLUE LED will turn off, indicating self-check has completed.
- Move the sticks bound to CH1~CH6 (except the stick related to Thr) and check the channel output limits, ensuring that the signal outputs of RB-30/RB-40 will not damage the corresponding parts on the model. In the end, RB-30/RB-40 will save the zero points of the gyro, auto level angle, gimbal neutral position and servo channel limits.

 Never operate the stick bound to CH12 during flight session or it will trigger self-check and may cause the crash of the model.

Setup

- Calibrate RB-30/RB-40 with the Lua.or Freelink App and install it into the model. Ensure the settings of wing type and mounting type are identical to the intended model installation.
- Turn on the transmitter and reduce the value of servo endpoint setting. Ensure self-check mode will not damage the corresponding parts on the model.
- Assign a knob/slider to CH9, then real-time gain adjustment capabilities of RB-30/RB-40 will be activated.
- Assign three-position switches to CH10 and CH11 with the purpose of switching available flight modes.
- Power on the model and check the deflection direction of each related parts on the model. Make sure the switch assigned to flight modes is correct and the compensation direction of the gyro is set as intended on AIL, RUD and ELE.
- Make a self-check for RB-30/RB-40 if necessary. Disconnecting the power on RB-30/RB-40 will not lose the set parameters.

 Under identical operating conditions, the value of each channel is produced by the assigned switch in FrOS are opposite to that in OpenTX. For example, SW Up in FrOS is equal to SW Down in OpenTX.

FrSky is continuously adding features and improvements to our products. To get the most from your product, please check the download section of the FrSky website www.frsky-rc.com for the latest update firmware and manuals